



www.nmnavyleague.com

April 2026

Spring 2026 Issue

Page 1

Navy News Reels for Operation Epic Fury

Page 2

**- President's Message:
NM Council Updates**

Pages 3-5

**- Local New Mexico News
Blue Star Care Packages
Albuquerque Sea Cadets
100-year-old "new" member
SSN-706 historical photos
Remembering Tom Gutierrez**

Page 5-7

**- From the Sea Chest
Encounter of USS New Mexico
(BB-40) and SS Sea Flasher**

Visit Sea Power magazine,
the official Publication of the
Navy League of the United States.
<https://seapowermagazine.org/>



Operation Epic Fury -- Navy News Reels *by Mark Schaefer, newsletter editor*

With the nation at war, there has been a lot of news about how the Navy is participating in Operation Epic Fury. Some of these stories are widely publicized. Others have been sent to me from some not so well-known news sources. All are true news. I hope you enjoy these "news reel" snippets of U.S. Navy contributions.

- U.S. submarine sinks Iranian warship by torpedo in a first since World War II – Iranian ship IRIS Dena shown in the Indian Ocean. Secretary of War Pete Hegseth called this "Quiet Death" and said, "We are fighting to win".
- Nearly 51-year-old USS Nimitz changed its former route to its decommissioning site in Naval Station Norfolk and had its service life extended to 2027 as part of the 3rd fleet in the Pacific.
- USS John F Kennedy, the Navy's 2nd Ford-class carrier, is scheduled to be delivered and commissioned in March 2027, keeping the carrier fleet at 11 ships after the Nimitz extension is complete.
- U.S. Central Command has confirmed that over 100 Iranian naval vessels have been destroyed or disabled including multiple frigates, corvettes, and catamaran warships, over 16 minelaying vessels, one Russian-built Kilo-class submarine capable of anti-ship missiles and torpedoes, and multiple midget submarines. Apparently, two other Kilo-class submarines were damaged in dry dock.
- Air Force A-10 Thunderbolt II aircraft and AH-64 Apache helicopters have been deployed. Typically used as tank-killers, these are now taking out small boats and minelayers and other boats being used in swarming tactics in the Strait of Hormuz.
- Work is in progress to control the Strait of Hormuz by a multi-national coalition, like the Panama Canal, instead of an Iranian-controlled strait.
- Iran fired two intermediate-range ballistic missiles at Diego Garcia in the Indian Ocean. Both missed this important US-UK military base.



Thank You! When you keep your dues up to date with the Navy League national office, our New Mexico council receives a stipend for each active member. This makes a big difference in our ability to help support our namesake ships, our youth, our Sea Cadets, and the local active and reserve.
Join or renew at members.navyleague.org

2026 COUNCIL OFFICERS

John L Jones
President

David F Williams
Vice President

Chuck Vaughan
Treasurer

David Minster
Secretary

COMMITTEE CHAIRS

Damon Runyan
USS New Mexico SSN-779

Ron Olexsak
USS Santa Fe SSN-763

**Lawrence Edwards
& Allen Tate**
*Albuquerque SSN-706
Sail Committee*

Greg Trapp
Historian

LTJG Patrick Williams
Reserve Liaison

Rebecca Vigil
Public Affairs

Ed Nava
Website Editor

NAVY LEAGUE
NEW MEXICO COUNCIL
P.O. Box 91554
Albuquerque, NM 87199

Mark Schaefer
Newsletter Editor
usnanm@comcast.net



Donations to the USS Albuquerque Memorial are now being accepted at this City of Albuquerque web site:

<https://one-albuquerque-fund.snwbll.com/uss-albuquerque-memorial>



President's Message



John Jones
President, New Mexico Council

Spring is Here – Eighty degree weather, but waiting for snow in April!

Our newsletter highlights Navy engagement in Operation Epic Fury, welcomes the new Albuquerque Battalion of Sea Cadets, and honors the efforts of the Rio Grande Blue Star Mothers supporting deployed New Mexicans. Our Historian, Greg Trapp, has also provided an in-depth article on battleship USS NEW MEXICO (BB 40) engaging with SS Sea Flasher in 1945.

Centennial birthday greetings to **ARM2c John Nagle** – and our newest Navy League member. Semper Fortis, John.

The JROTC units will begin their annual awards ceremonies in late April and early May. The Council provides a Theodore Roosevelt Award (medal, ribbon and citation) to units that notify us of a recipient. We support JROTC units across the State and portions of El Paso, Texas. We make every attempt to present these awards in person, but it CAN be logistically challenging. If you'd like to represent the Navy League at a ceremony in your community, let us know!

Increasing membership remains a high priority this year. The Council depends on passionate individuals, like you, and corporate sponsors to support our mission – please tell your friends about us!

The NM Council has adopted ships, honored and rewarded local enlisted personnel, and supported families of deployed sea service personnel. We've worked at the national level to educate government officials on the maritime nature of our Nation and New Mexico's links to the sea. No prior military service is required to be a member of the League. Active-duty service members are now eligible for membership, and the spouses of those currently serving can join at no cost for one year - just our way to thank you for all you do.

Please consider a tax deductible donation to the Council in support of our educational efforts with the Sea Services, our scholarship program for men and women on active duty and in the reserves, our work with crews on our namesake New Mexico ships, and our recognition programs with the Navy ROTC and Junior Navy and Marine Corps ROTC programs around the State and El Paso.

The 251st Navy Birthday Ball will be held on October 17th this year, at Isleta Resort & Casino ... we'll be honoring the 250th anniversary of the Birth of our Nation.

The Council Board continues to meet via Zoom on the 2nd Monday of each month. Should you wish to sit in on a meeting, let me know!

Lastly – Fair Winds and Following Seas to Ralph Thomas Gutierrez, a Captain of Seabees, Marine aviator, Native Son of New Mexico, Naval Academy graduate, and tireless supporter of the Navy League mission. Godspeed, Tom – I am honored to call you Friend.

Stay in touch, tell us what you think.

Contact me any time at
JohnLJonesNM@gmail.com
or by mail at the Council's P.O. Box.
Not for Self, but Country. Semper Fortis.

John L Jones, CDR SC USN (ret)



Navy League New Mexico Council Helps Blue Star Mothers Send More Care Packages to Deployed Ships and Units *by Damon Runyan*

On Saturday, March 14th, the Rio Grande Valley Blue Star Mothers held a packing event at their warehouse on 2nd St. NW in Albuquerque. Three grizzly veterans from the New Mexico Council were among about 80 people that showed up to pack and send



goodie boxes to deployed units all over the world. The volunteers packed right at 200 boxes for our service members. As always, we honor and admire all that the RGV Blue Star Mothers do for our dedicated active-duty Americans away from their families.



David Williams, John Jones, and Damon Runyan represented the Navy League, New Mexico Council at the Blue Star Mothers packing event that drew quite a few volunteers from all branches of military service.

Albuquerque Sea Cadets

from Thurraya Kent, Strategic Growth Director, U.S. Naval Sea Cadet Corps

I'd like to introduce you to the commanding officer of your local Sea Cadets unit, William (Bill) Tutunjian. The Albuquerque Battalion drills at the University of New Mexico.

We hope you will consider partnering with the new Sea Cadets unit. The unit would benefit from veterans and community leaders attending meetings (drills) as guest speakers or volunteers. Topics of interest include seamanship, leadership, first aid, law enforcement, preparation for maritime trades, U.S. flag protocol, military drill, public speaking, military history, and New Mexico history. Additionally, consider inviting Albuquerque Battalion to join you at parades, community service projects, and other events to support military veterans, first responders, and neighbors in need.

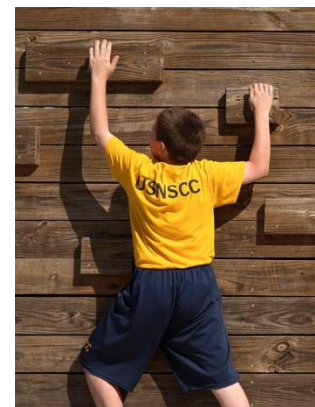

To learn more about Albuquerque Battalion, contact Bill Tutunjian at co.191abq@seacadets.org. Thank you for your continued support of Sea Cadets!

New Member of New Mexico Council is 100-years-old *story by David Williams*



John Nagle and CDR David Williams

Past New Mexico Council President David Williams represented the council at the 100th birthday party for John Nagle, WW2 Navy 2nd Class Aviation Radio/Gunneryman (ARM2c). The event was attended by Navy representatives from Defense Threat Reduction Agency on Kirtland AFB and the Navy Reserve Center. Current President of the New Mexico Council, John Jones, authorized a complimentary one-year Navy League membership which was presented in a letter of appreciation, along with our 250th Birthday Ball Commemorative Coin. The event was attended by over fifty family, friends, Albuquerque Fire Rescue truck and crew, plus two Albuquerque Police units. Mr. Nagle is in amazingly good condition, does his own yard and housework, and still drives. He plans to attend our next Birthday Ball and possibly some Navy Network events.



USS Albuquerque (SSN-706) Historical Photos Preserved *story by Mark Schaefer*

Albuquerque submarine veteran Terry Owen took on a task to report to the Albuquerque Historical Society about the former submarine USS Albuquerque (SSN-706), its history of contributions to the defense of our country, and its progress on being turned into a monument. Terry did a great job of it, and the Albuquerque Historical Society posted a copy of his presentation and slides at this link → <https://www.youtube.com/watch?v=PYInkXiVIPk>. You can watch this presentation by typing the link into your browser. We will also post the link on the Navy League of the United States, New Mexico Council website (see link at the bottom of each page of the newsletter).



USS Albuquerque's Roadrunner Grill in 2015

As part of the research for this presentation, Terry asked council members for certain photos of the crew's mess of the Albuquerque. It was a unique crew's mess affectionately named the Roadrunner Grill. After digging deep, council member Dick Brown uncovered a virtual treasure trove of photos of the Albuquerque. There were also quite a few presentations that Dick had put together over the years. With some concern from our council historian, Greg Trapp, that digital-only history is being lost, Mark Schaefer sought out the two laptops that had the items from Dick Brown. All the



USS Albuquerque officers and a ship's rider play cribbage in the wardroom while underway in 2015.

Albuquerque photos and documents are now in the process of being preserved on a Drop Box site that will be shared in the newsletter next quarter.

In Memory of CAPT Ralph "Tom" Gutierrez *by Mark Schaefer*



Tom Gutierrez

The New Mexico Council pays its respects to Past Council President Tom Gutierrez who passed away on December 5, 2025. Tom held several officer roles in the New Mexico Chapter, and he was a great supporter of the Navy.

Commissioned into the Marine Corps as a Second Lieutenant in the Naval Academy's class of 1970, Tom completed The Basic School (TBS) in Quantico, VA and NFO school in Pensacola, FL. As a Radar

Intercept Officer, he was stationed in Kaneohe Marine Corps Air Station in Hawaii. During a civilian career with Gas Company of New



Rebecca Vigil and Tom Gutierrez on board the submerged USS New Mexico in 2010

Mexico and later at the Department of Energy, Tom became a Naval Reserve officer and attained the rank of Captain. Tom was a dedicated Blue and Gold Officer for over 25 years, working beside his spouse Rebecca Vigil to bring the Naval Academy and the Navy Admissions staff some of the best students that New Mexico had to offer.

For the Navy League, Tom was dedicated to honoring our JROTC cadets and regularly presented the Teddy Roosevelt Awards to schools across the State. Tom earned the New Mexico Council's highest award and was presented it at an annual meeting by then-President Dave Williams. Always one to cheer on Navy football at the Alumni events, Tom will be missed at those events and in the many ways he served the country, the State of New Mexico, our students and recruits, our namesake ships, and our Council.



Tom receives New Mexico Council recognition from past-president Dave Williams



From the Sea Chest — by Greg Trapp, JD, Chapter Historian

Author's Note and Acknowledgement: I gratefully acknowledge Mark Thomason who brought this incident to my attention. His father, Leonard Joe Thomason, was an Army Medical Supply Tech with the 53rd Medical Group. He was aboard SS Sea Flasher and witnessed the carnage that unfolded on May 3, 1945

Carnage at Okinawa; The Tragic Encounter of USS New Mexico and SS Sea Flasher

by Greg Trapp, JD

The fierce and bloody Battle of Okinawa took place from the 1st of April through the 22nd of June 1945. The plan to capture Okinawa was code named Operation Iceberg, and the invasion fleet included the veteran battleship USS New Mexico (BB-40). USS New Mexico was assigned to provide fire support as a part of Task Force 54 and served as flagship for 5th Fleet Commander Admiral Raymond Spruance. The Japanese recognized that they had already lost the war, but they hoped to inflict such heavy casualties at Okinawa that the Allies would be forced to postpone the home island invasion and offer more favorable peace terms. That decision would lead to the deaths of over 110,000 Japanese military personnel and over 100,000 Okinawan civilians. The Battle of Okinawa would also cost the lives of over 12,000 Army, Navy, Marine, Coast Guard, and Merchant Marine personnel. This toll was more than perished in the battles of Tarawa, Peleliu, and Iwo Jima combined. One of those who died during the battle was war correspondent Ernie Pyle who was hit by Japanese machine-gun fire on April 18. The fallen also included 54 sailors who died after a kamikaze struck USS New Mexico on May 12. The carnage additionally included seven soldiers who perished on the troop transport SS Sea Flasher. Those seven lives were not lost due to direct enemy action, but rather to the chaos of what would ultimately be the largest and most deadly battle of the entire Pacific Theater.



*An aerial view of USS New Mexico, BB-40
(Official U.S. Navy Photo).*

The Battle of Okinawa was horrific even by the extreme standards of the Pacific War. The island of Okinawa was just 360 miles from the Japanese home island of Kyushu, and Allied war strategy called for the invasion of the home islands to be launched from Okinawa. Japanese war planners knew the Allies would need to use Okinawa as a staging area for the invasion, and the Japanese had committed a large portion of their carefully hoarded military reserves to the battle. Japanese General Mitsuru Ushijima also knew from Peleliu and Iwo Jima that it was possible to draw the Americans into a protracted battle of attrition. He also saw an opportunity to use the terrain and natural fortifications of Okinawa to his advantage. Okinawa was nearly 70 miles long and 7 miles wide, and the large land mass and hilly terrain enabled Ushijima to establish multiple defensive networks protected by camouflaged artillery, mortars, and machine guns. An extensive system of tunnels also enabled Japanese troops to maneuver between defensive positions and to infiltrate Marine and Army lines.

The invasion landings took place on April 1 and were essentially unopposed. The fighting became ferocious once Army and Marine troops reached the fortified Japanese positions that were located further inland. The Marines had been supported by Navajo Code Talkers throughout the Pacific War, and the Code Talkers were especially critical during the Battle of Okinawa. The American troops were hampered by the early arrival of monsoon rains, which caused muddy conditions that limited the use of tanks and armored vehicles. Okinawa also had a large civilian population which were frequently caught in the crossfire. These civilians had been told by the Japanese Army that they would be raped or



From the Sea Chest — by Greg Trapp, JD, Chapter Historian

(Carnage at Okinawa: *continued from previous page*)

tortured by the Americans, and large numbers were convinced to commit suicide. The civilian casualties also included Okinawan males aged 14 to 17 who were pressed by the Japanese Army into military service and females who were required to serve as nurses. The Marine and Army troops ashore also faced shortages of food and ammunition due to frequent kamikaze attacks on the American fleet. Kamikaze pilots especially targeted destroyers, supply ships, and landing craft because those vessels were lightly armed and more vulnerable to attack.

The Japanese use large waves of coordinated kamikaze attacks throughout the Battle of Okinawa. The first large wave of kamikaze attacks was launched on April 6. The Japanese also launched Operation Ten-go on that same day, which sent the super battleship Yamato and her 18.1-inch guns on a suicidal sortie to attack the Allied invasion force. However, American intelligence learned of the plan, and Yamato was sunk after being attacked by over 280 American planes. The relentless kamikaze attacks would prove far more effective than the ill-conceived Operation Ten-Go. Between 1,500 and 2,000 kamikazes were launched during the Battle of Okinawa, and they sank over 30 Allied ships and damaged another 368 ships.

Many of the ships that were lost or damaged at Okinawa were crewed by Merchant Marines. The Merchant Marines were critical to the war effort

and suffered a higher casualty rate than any other branch of the military. The Merchant Marines crewed ships that were operated by the War Shipping Administration (WSA). A total of 170 WSA ships delivered troops, ammunition, fuel, food, and equipment during the Battle of Okinawa. One of those was SS Hobbs Victory, which was named after the New



40 mm Bofors

Mexico town. Two kamikazes attacked SS Hobbs Victory On April 6, setting the ammunition ship ablaze and causing the deaths of eleven Merchant Marines and one Navy Armed Guard. The burning Victory ship sank the next day after the fires caused the ammunition to explode. Another of the War Shipping Administration ships at the Battle of Okinawa was SS Sea Flasher. The C3 cargo ship was transporting 1,609 Army soldiers and had a crew of 61 Merchant Marines and 43 Navy Armed Guards. The job of the Navy Armed Guard on a WSA ship was to man the ship's guns, typically consisting of a single 5 inch or 3-inch gun, along with a handful of Bofors 40 mm and Oerlikon 20 mm guns. The Bofors 40 mm gun was one of the most effective anti-aircraft guns of World War II. The Swedish-designed gun was configured in twin and quad mounts and could fire up to 120 rounds per minute. The crews that manned these guns were in exposed positions with nothing more substantial than a helmet for protection.



USS New Mexico was attacked by two kamikazes on May 12, 1945. The attack killed 54 sailors and wounded another 119. This photo was taken on May 13 and shows the funeral service for the sailors who were killed in the attack. (Official U.S. Navy Photo).

The success of Japanese air attacks resulted in large numbers of 40 mm and 20 mm guns being installed on Navy ships, including USS New Mexico. The battleship was the flagship of 5th Fleet Commander Admiral Raymond Spruance, and the crew knew they were a prime target for Japanese kamikaze attacks. The deck log from that day reveals that the battleship was in a condition of heightened readiness for attacks from “suicide planes” and “suicide boats.” The deck log also reveals the strain of being on constant alert, with two sailors being disciplined for having fallen asleep while on watch. New Mexico had also been struck by a kamikaze four months earlier during the Philippine Campaign, and the crew knew the devastating damage that such a strike could cause.

The crew of New Mexico’s number 2 40 mm gun were drilling on the afternoon of Thursday, May 3. New Mexico was Anchored in berth HOW 159, Hagushi Anchorage. Just 800 yards off New Mexico’s port beam was SS Sea Flasher. The 40 mm gun was loaded with live ammunition, and at 1618 hours 8 rounds were accidentally fired into SS Sea Flasher. The deck log describes the incident as follows,

“While the crew of 40 mm mount number 2 were exercising at loading drill the mount accidentally fired eight rounds of HEIT ammunition into the SS Sea Flasher.” The mishap tragically killed seven soldiers and wounded another 47 soldiers.

The next day an Army investigatory team came aboard USS New Mexico. The results of that inquiry are unknown, but it is likely that the extreme stress of the Battle of Okinawa played a role in the accident. The Bofors 40 mm gun was fired by means of a foot pedal, and a momentary lapse of attention or a sudden slip could have caused the accidental discharge.

The Battle of Okinawa and its aftermath continue to resonate more than eighty years after the end of the fighting. It is remembered for many things, including the huge loss of life, the joint nature of the action that included all branches of the military, the tragic civilian casualties, the intense kamikaze attacks, the courage of sailors who fought to save their stricken ships, and for the ferocity of the fighting. The sacrifice made of those lost and wounded on SS Sea Flasher should also be remembered, along with the sacrifices of the Merchant Marines and Navy Armed Guard who helped to make victory possible.

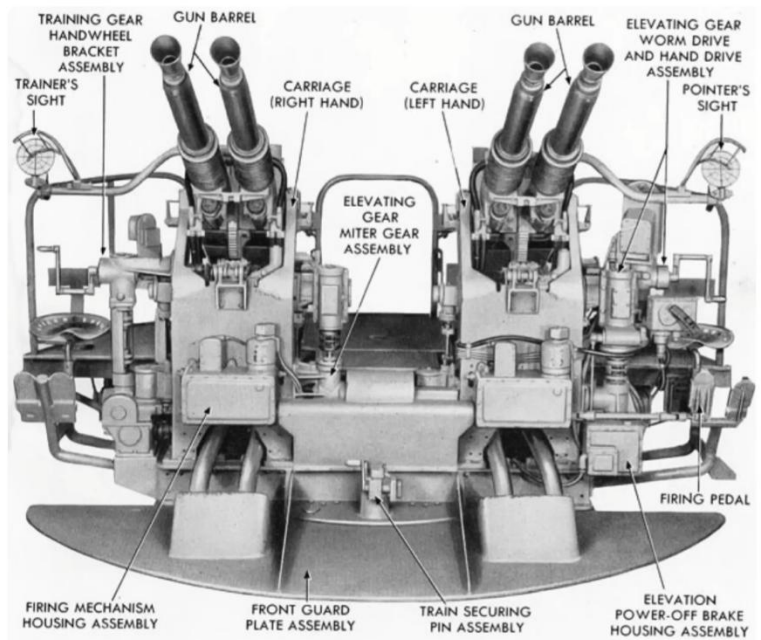

SS Sea Flasher is shown here on November 10, 1945. The ship is being used to repatriate Japanese prisoners of war. SS Sea Flasher survived the war and was sold into civilian service and renamed SS Steel Age. (AP Wire Service Photo).

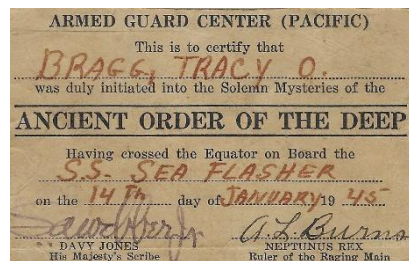

Maritime traditions are deeply engraved in the hearts and minds of sailors. Shown here is a very simple “crossing the line” card that was presented to a member of the Navy Armed Guard when SS Sea Flasher crossed the Equator on January 14, 1945 (Collection of G. Trapp).



Shown here is a 40 mm “dummy” training round placed next to a half gallon milk carton for size comparison (Collection of G. Trapp).

NAVY LEAGUE OF THE UNITED STATES
NEW MEXICO COUNCIL
P.O. BOX 91554
ALBUQUERQUE, NM 87199
Return Service Requested

The Navy League New Mexico Council thanks
ABQ Grafix
for their continued service to country
via discounted printing of the NM Nautical News!
3700 Osuna Rd. NE, #501
Albuquerque, NM 87109



iprint@abqgrafix.com



Navy League of the United States New Mexico Council, P.O. Box 91554, Albuquerque, New Mexico 87199-1554. The Navy League is classified by the IRS as a 501(c)(3) non-profit organization and your donation is tax-deductible.

2026 Upcoming Events for Navy League, New Mexico Council

April 13	Navy League, New Mexico Council board meeting via Zoom
May 11	Navy League, New Mexico Council board meeting via Zoom
June 8	Navy League, New Mexico Council board meeting via Zoom
October 17	251st Navy Birthday Ball 2026 – Isleta Resort & Casino